





PixelNext®

DisplayCORE® - Industrial by Design™

3.9" 480x128 Instrument Grade HDMI DISPLAY with
Optical Film Enhancement

P/N: 82-091-00 REV 01

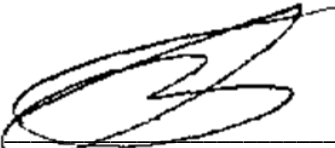
TARGET SPECIFICATION – Preliminary Release (controlled)

<p>Approved: Product Manager</p>  <p>01/02/2022</p> <p>Signature Date</p>	<p>Approved: Doc Control</p>  <p>01/02/2022</p> <p>Signature Date</p>
--------------------------------------------------------------------------------------------------------------------------------------------------------------	-----------------------------------------------------------------------------------------------------------------------------------------------------------

REVISION HYSTORY

Version	Date	Section	Comments
REV 00	11/10/2021	All	Preliminary Release
REV 01	01/02/2022	1.1, 1.3	Remove Touch Reference, Add 2D Drawing

Contents

1. MECHANICAL SPECIFICATION	4
1.1 GENERAL SPECIFICATIONS	4
1.2 3D DRAWING	5
1.3 2D DRAWING	6
2. CONNECTORS ASSIGNMENT	7
2.1 J1 – POWER	7
2.2 J2 – HDMI	7
2.3 J3 – PWM	7
2.4 J4 – USB TOUCH (ONLY ACTIVE ON 82-090-00)	7
4. OPERATION SPECIFICATIONS	8
4.1 TFT ABSOLUTE MAXIMUM RATINGS	8
5. OPTICAL SPECIFICATION	8
A. TEST CONDITIONS	8
B. OPTICAL CHARACTERISTICS	8
6. ENVIRONMENTAL / RELIABILITY TEST CRITERIA	11
7. PRODUCT COMPLIANCE	11
A. FCC DECLARATION	11
B. UL MATERIAL DECLARATION	11
8. PRECAUTIONS	12
A. ASSEMBLY AND HANDLING PRECAUTIONS	12
B. SAFETY PRECAUTIONS	12

1. MECHANICAL SPECIFICATION

1.1 GENERAL SPECIFICATIONS

NO	Item	Specification	Remark
1	LCD Size	3.9 inch (Diagonal)	
3	Resolution	480x128 Landscape	
4	Display mode	a-Si Normally White with O-Film Enhancement	
5	Luminance	400 cd/m2 typical	
6	Contrast Ratio	500 typical	
7	Dot pitch	0.198(H) × 0.198(V)	
8	Active area	95.04(H) × 25.34(V)	
9	Module size	130.64 × 40.64 × 28.3 mm	Note 1
10	Surface treatment	Glare	
11	Color arrangement	RGB-stripe	
12	TFT Interface	HDMI	
13	Display Colors	16.7M	
14	Touch Interface	Not Included	
15	Backlight power consumption	0.68 Typical	Watts
16	Module power consumption	1.0 Typical	Watts
17	Weight	TBD	

Note 1: Refer to Mechanical Drawing. Maximum distance includes PWM connector.

1.2 3D DRAWING

SLDPRT Model available upon request

CONFIDENTIAL

1.3 2D DRAWING

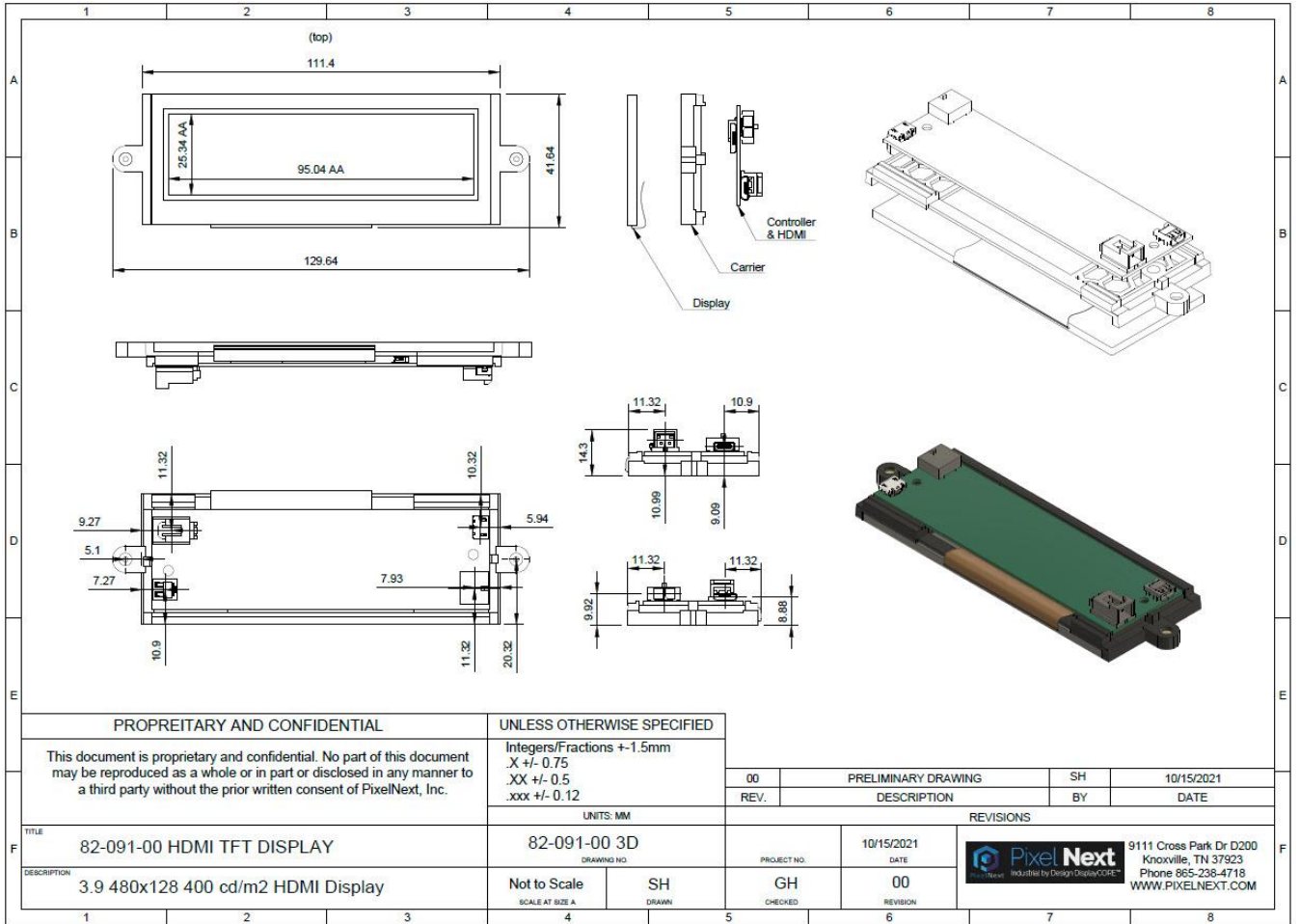

2 CONNECTORS ASSIGNMENT

2.1 J1 – POWER

Pin	Name	Description
1	GND	Ground
2	PWR	Power – (5V DC)

TE CONNECTIVITY P/N 2-1445098-2

FPC Connector HD1S040HA1 or compatible. Manufacturer JAE or compatible

2.2 J2 – HDMI

Pin	Name	Description
1	TMDS Data2+	Digital Input Channel 2 True
2	TMDS Data2 Shield	Ground
3	TMDS Data2-	Digital Input Channel 2 Complement
4	TMDS Data1+	Digital Input Channel 1 True
5	TMDS Data1 Shield	Ground
6	TMDS Data1-	Digital Input Channel 1 Complement
7	TMDS Data0+	Digital Input Channel 0 True
8	TMDS Data0 Shield	Ground
9	TMDS Data0-	Digital Input Channel 0 Complement
10	TMDS Clock+	
11	TMDS Clock Shield	Ground
12	TMDS Clock-	
13	CEC	Control
14	Reserved/HEC Data-	No Connection
15	SCL	DDC clock
16	SDA	DDC data
17	DDC/HEC/CEC Ground	Ground
18	+5 V Power	power EDID/DDC
19	Hot Plug Detect/HEC Data+	

Molex Micro D 0467652001

2.3 J3 – PWM

Pin	Name	Description
1	LCD_PWM	3.3V PWM Signal 100 KHz Max Freq (Pull Up Default)
2	GND	Ground

Molex 70553-0001 (Mating 0015474023)

2.4 J4 – USB TOUCH (ONLY ACTIVE ON 82-090-00)

Pin	Name	Description
1	VCC	5 Volts
2	D-	Data -
3	D+	Data +
4	GND	Ground
5	NC	No Contact

Molex Micro B 1050170001

4. OPERATION SPECIFICATIONS

4.1 TFT ABSOLUTE MAXIMUM RATINGS

The followings are maximum values which, if exceed, may cause faulty operation or damage to the unit.

Item	Symbol	MIN	TYP	MAX	Unit
Supply Voltage	VDD	4.85	5.00	5.25	V
Operating Temperature	TOPR	-20	-	70	°C
Storage Temperature	TSTG	-30	-	80	°C

5. OPTICAL SPECIFICATION

A. TEST CONDITIONS

Item	Symbol	Value	Unit
Ambient Temperature	T _A	25±2	°C
Ambient Humidity	H _A	50±10	%RH

B. OPTICAL CHARACTERISTICS

Item	Symbol	Condition	Min	Typ	Max	Unit	Note
Contrast Ratio	CR	$\Phi=\theta=0^\circ$	400	500			1, 3
Viewing Angles	ΦT	CR≥10	60	70		°	2
	ΦB		70	75			
	ΦL		70	75			
	ΦR		70	75			
Luminance	L		350	400		cd/m ²	1, 5
Uniformity	U		75	80		%	1, 6
LED Lifetime				25,000		Hours	7

Note 1: Definition of optical measurement system.

The optical characteristics should be measured in dark room. After 10 minutes operation, the optical properties are measured at the center point of the LCD screen. All input terminals LCD panel must be ground when measuring the center area of the panel.

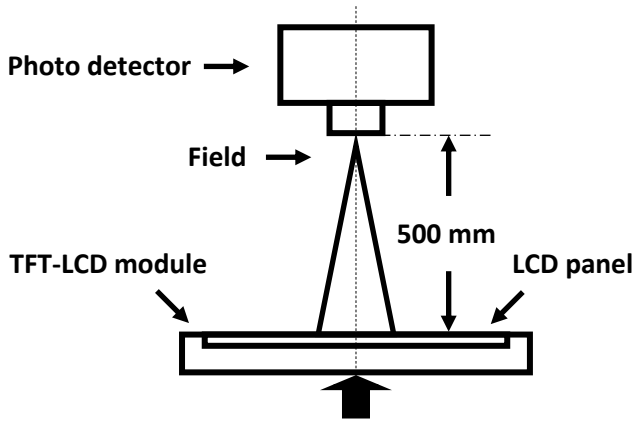

Item	Photo detector	Field
Contrast Ratio	SR-3A	1°
Contrast Ratio	BM-7A	2°

Note 2: Definition of viewing angle range and measurement system.

Viewing angle is measured at the center point of the LCD by CONOSCOPE (ergo-80)

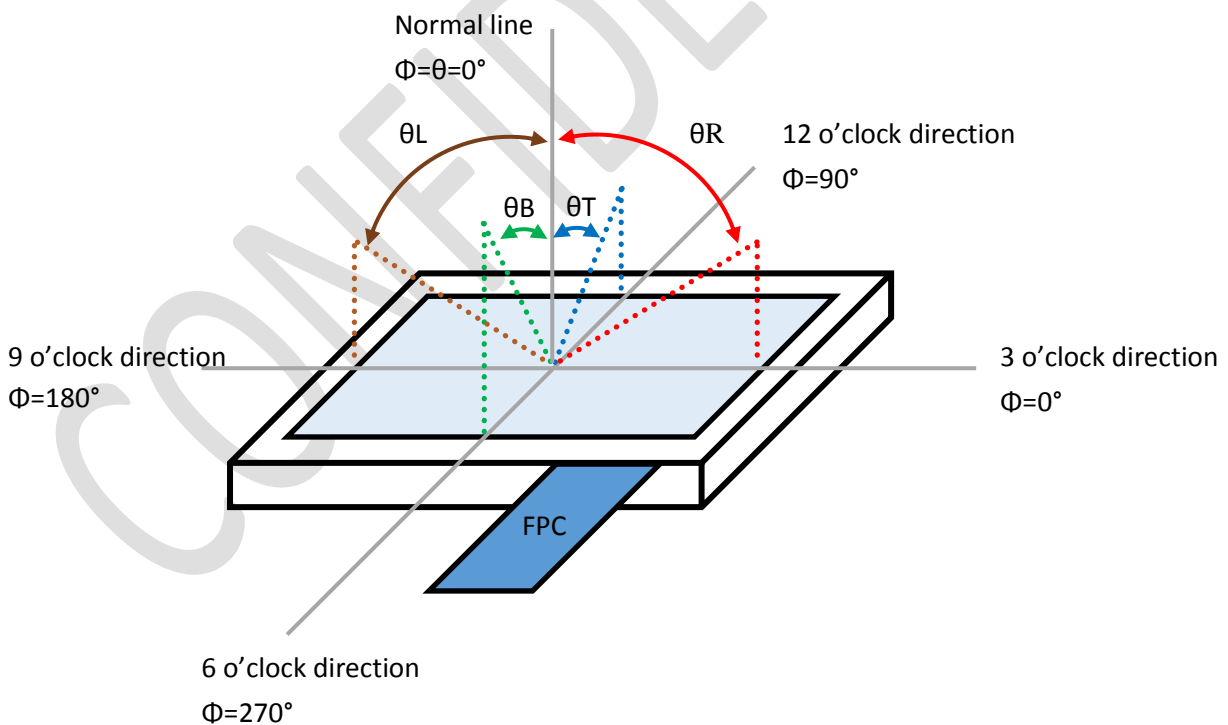

Note 3: Definition of contrast ratio.

$$\text{Contrast Ratio (CR)} = \frac{\text{Luminance measured when LCD is on "White" state}}{\text{Luminance measured when LCD is on "Black" state}}$$

“White” or “Black” state: the state at which the LCD is driven by Vwhite or Vblack

Note 4: Response time.

Response time is defined as the LCD optical switching time interval between “White” and “Black” state. Rise time (TON) is the time for photo detector output intensity to change from 90% to 10%. Fall time (TOFF) is the time for photo detector output intensity to change from 10% to 90%.

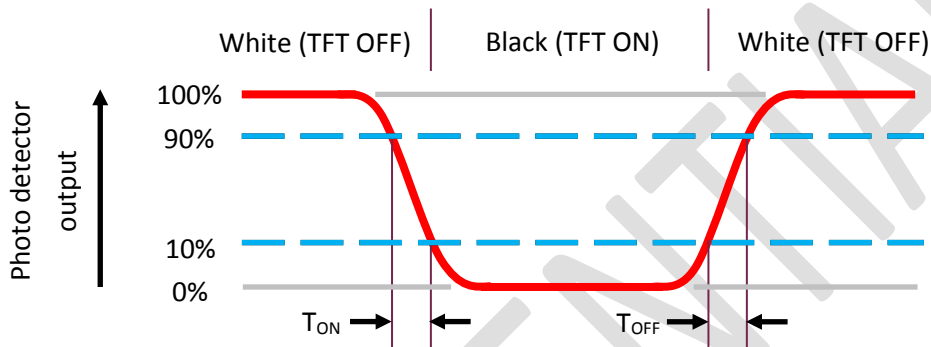

Note 5: Definition of Luminance.

It is the measurement of white state at center point. Left/Right 0° | Top/Bottom 5°

Note 6: Definition of Luminance Uniformity.

The Active Area is divided into 9 measuring areas. Every measuring point is placed at the center of each measuring area.

Lmax: the measured Maximum luminance of all measurement positions.

Lmin: the measured Minimum luminance of all measurement positions.

$$\text{Luminance Uniformity} = \frac{L_{\min}}{L_{\max}} \times 100$$

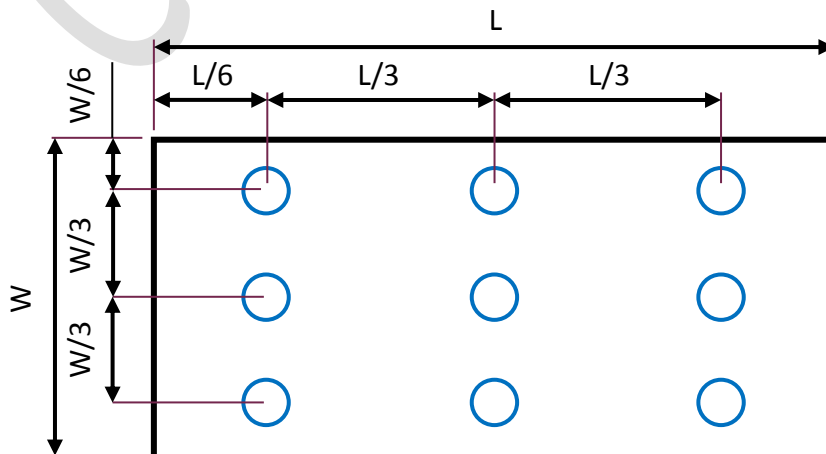

Note 7: Definition of If LED lifetime.

LED lifetime is defined as the time in which it continues to operate under the ambient condition of $T_a=25\pm 3^\circ\text{C}$, typical IF value, and until the brightness is less than 50% its original value. Typical operating lifetime is an estimated data. Lifetime of LED is reduced when it is driven by high current, high ambient temperature, and humidity conditions.

6. ENVIRONMENTAL / RELIABILITY TEST CRITERIA

N.	Test Item	Condition	Judgement Criteria
1	High Temperature Operation	$T_A = +70^\circ\text{C}$, 96h	See table below
2	Low Temperature Operation	$T_A = -20^\circ\text{C}$, 96h	See table below
3	High Temperature Storage	$T_A = +80^\circ\text{C}$, 96h	See table below
4	Low Temperature Storage	$T_A = -30^\circ\text{C}$, 96h	See table below
5	High Temperature & High Humidity Storage	$T_A = +60^\circ\text{C}$, 90% RH, 96h	See table below (polarizer discoloration is excluded)
6	Thermal Shock (non-operation)	-30°C , 30min \leftrightarrow $+80^\circ\text{C}$, 30min 5 min. change time, 5 cycles	See table below
7	ESD (operation)	Air discharge: $\pm 8\text{kV}$ Contact discharge: $\pm 4\text{kV}$	See table below
8	Vibration (non-operation)	10Hz~150Hz, 100m/s^2 , 120 min	See table below
9	Shock (non-operation)	Half-sine wave, 300m/s^2 , 11ms	See table below
10	Package drop test	Height: 80cm 1 corner, 3 edges, 6 surfaces	See table below

Inspection Item	Criteria
Appearance	No crack on FPC, or on the LCD panel
Alignment of LCD panel	No bubbles in the LCD panel No other alignment defects in the Active Area
Electrical current	Within device specification
Function / Display	No broken circuits, no short circuit or no black line No other functional defects of display

7. PRODUCT COMPLIANCE

A. FCC DECLARATION

B. UL MATERIAL DECLARATION

20-001-01, 20-002-01 Gaskets – 3M VHB RP25 - UL746C

8. PRECAUTIONS

A. ASSEMBLY AND HANDLING PRECAUTIONS

- (1) Do not apply rough force such as bending or twisting to the module during assembly.
- (2) The assembly or installation of the module into user's system can be only done in clean working areas. Dust and oil may cause electrical short or worsen the polarizer.
- (3) Do not exercise pressure or impulse on the module because the LCD panel and backlight will be damaged.
- (4) Always follow the correct power sequence when LCD module is connecting and operating. This can prevent damage to the CMOS LSI ICs during latch-up.
- (5) Do not pull the interface connector or cable in or out while the module is operating.
- (6) Do not disassemble the module.
- (7) Use a soft dry cloth without chemicals for cleaning, because the surface of polarizer is very soft and easily scratched.
- (8) It is dangerous when moisture comes into contact with the LCD module, because moisture may damage LCD module when it is operating.
- (9) High temperature or humidity may reduce the performance of module. Please store LCD module within the specified storage conditions.
- (10) When ambient temperature is lower than 10°C it may reduce the display quality. For example, the response time will slow.
- (11) Do not keep same pattern for a long period of time. It may cause image sticking on LCD.

B. SAFETY PRECAUTIONS

- (1) Do not disassemble the module or touch the backlight array.
- (2) If the liquid crystal material leaks from the panel, it should be kept away from eyes or mouth. In case of contact with hands, skin, or clothes, it has to be washed away thoroughly with soap.
- (3) After the module's end of life, it is not harmful in case of normal operation and storage.